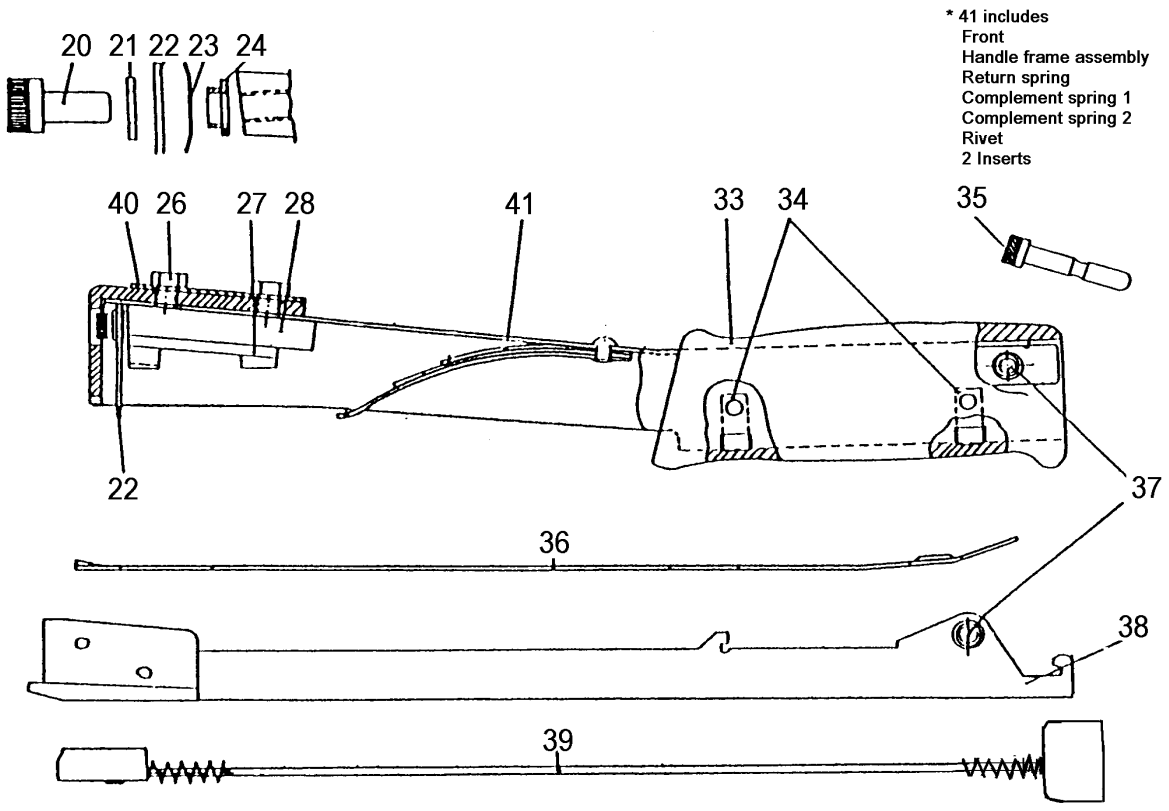

Created by rooh	Approved by rooh	Approval Date 2018-03-21	Page 1(1)	Class	No. 197517	Rev. 06
Info		Product Name R54 Spare parts				

Not to be disclosed outside of ISABERG RAPID AB without the consent of CEO or TPM.

220276	Pos No	Part No	Part Name	Qty
 <p>* 41 includes Front Handle frame assembly Return spring Complement spring 1 Complement spring 2 Rivet 2 Inserts</p>	20	822027600	Screw	1
	21	815522600	Washer	1
	22	714971610	Driver	1
	23	815527588	Washer spring	1
	24	814935100	Spacer	1
	26	822027800	Screw	2
	27	814964100	Damper	1
	28	814972400	Balance block	1
	33	814932800	Handle	1
	34	814965800	Guide	2
	35	714981500	Pin	1
	36	714958310	Lid	1
	37	814963300	Bushing	4
	38	714975705	Magazine	1
	39	714992200	Feeder complete	1
	40	714966600	Weight	1
	41 *	14969020	Handle frame assembly	1

When ordering always state the part numbers
 Head office and factory: ISABERG RAPID AB, Box 115, S-335 03 Hestra, Sweden
 Telephone 46-(0)370-33 95 00. Telefax 46-(0)370-33 95 02.
 Internet www.isaberg-rapid.com